



RKDOORSYSTEMS

Let's make an entrance

Entre door profile

The Entre profile benefits from a 65mm thick insulated panel construction and is flush both internally and externally with a flush contemporary frame. This door system offers an affordable door option with high performance and low U values for all residential and non-fire rated commercial entrances.

Performance ratings

- Water tightness: **Class 5A**
- Wind load resistance: **Class C2**
- Air permeability: **Class 4**
- Thermal transmittance: **0.90W/m² K**
- Sound insulation: **42dB**
- Security Certification: **Secure by Design / PAS 24 / RC2 / RC3**



Features & benefits

- ✓ German 65mm deep insulated frame with mechanical & glued corners for high performance construction and life expectancy
- ✓ Marine grade powder coat finish as standard suitable for all locations
- ✓ 65mm laminated triple glazing as standard for maximum security
- ✓ Extensive choice of external and internal colours giving maximum design choice
- ✓ Low level threshold as standard for disability access compliance
- ✓ Triple gasket sealing system for high weather performance
- ✓ Hidden fixing system with cover trims to frame & door sash for minimal maintenance and clean look appearance
- ✓ 316 Grade Stainless steel handles & fittings suitable for all locations
- ✓ Sidelights and fanlights in single frame construction offering minimal frame design
- ✓ Optional custom design or glass etching for individual design
- ✓ Available with motorised locking for use with finger scan locking systems and home smart properties
- ✓ Secure By Design and PAS 24 Certified for full new build compliance
- ✓ Optional 25mm high projecting cills for ease of installation



Secured by Design



Official Police Security Initiative

Specification

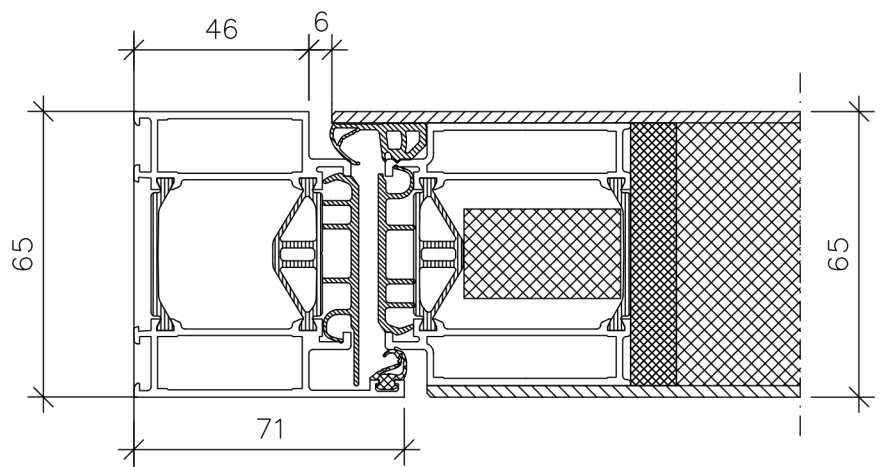
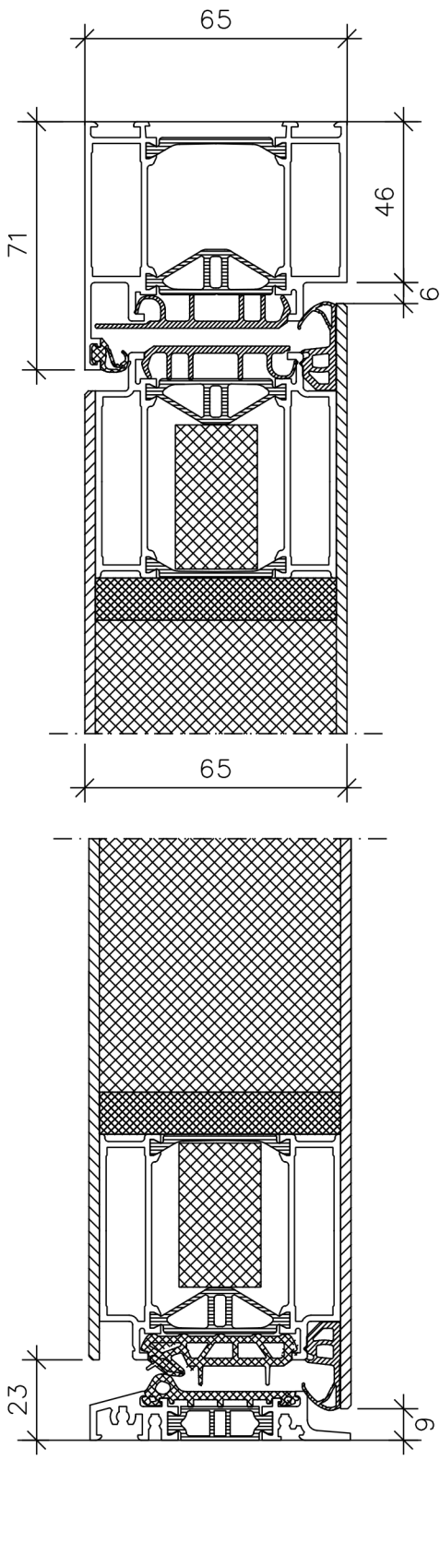

Dimensions	Frame depth	65mm
	Door sash depth	65mm fully insulated
	Visible frame (single door)	71mm
	Visible frame (with sidelight or fanlight)	65mm
	Glass thickness	65mm triple security glass
	Max single opening door width	1280mm (incl frame)
	Max single opening door height	2400mm (incl frame)
	Max sidelight width	1400mm
	Max fanlight height	1600mm
Frame & Design Options	Flush square	✓
	Glass Sidelights	✓
	Glass Fanlights	✓
	Opening Sidelights	✓
	Pair of doors	✓
	Outward opening	✓
	Custom Designs	✓
	Frame extensions	✓
Colour & Finish Options	16 Standard RAL colours	✓
	Non standard RAL colour	✓
	Timber finishes	✓
	Metallic Colours	✓
	Dual finish	✓
	Matt or Finestructure finish	✓